

Build it right
with Real Cedar

PLANTER BOXES, BENCHES & TABLES

Design ideas for
enhancing
outdoor living

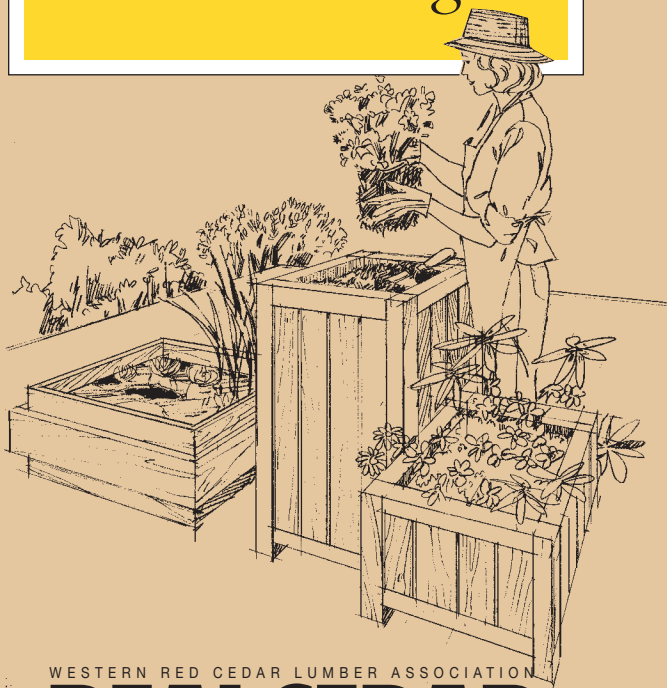

WESTERN RED CEDAR LUMBER ASSOCIATION

REAL CEDAR



REAL CEDAR FOR YOUR GREAT OUTDOORS.

Western Red Cedar is perfectly suited for your outdoor projects. Naturally decay-resistant, light in weight, easy to work, this durable wood is as practical as it is good looking.

This brochure contains helpful pointers on constructing a selection of planters, benches and tables. We have not included step-by-step building instructions as the designs are simply a source of ideas – concepts you can build on to meet your own outdoor living needs.

CEDAR, NATURALLY.

For centuries Western Red Cedar has been the Pacific Northwest's "heritage" outdoor building material – for some very natural reasons:

Natural durability. Cedar's natural preservative oil eliminates the need for further chemical treatments, unless the wood is in direct contact with the ground.

Natural stability. Cedar resists cracking, warping, cupping and pulling loose from fasteners.

Natural working ease. Cedar is uncommonly light in weight, cuts cleanly and easily.

Natural beauty. Cedar's richness of grain, color and texture complement any architectural style.



THE BASIC BOX

The basic box is an attractive container for a potted plant. Or line it with boards, plus an envelope of polyethylene, and it can hold soil and a variety of colorful plants.

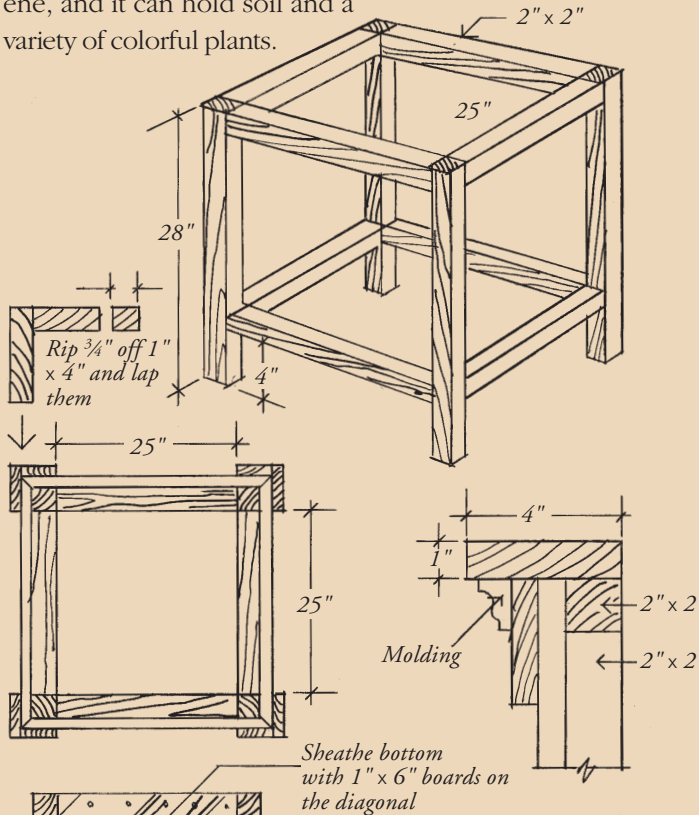

CREATE A DIFFERENT LOOK

Create your own designs using Cedar siding, lath or V-groove Cedar. As well as mixing and matching the outside look of your boxes, vary the heights and base dimensions to achieve eye-catching variety in planter groupings.

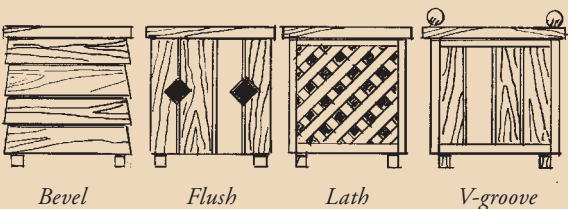

BENCH/PLANTER MODULES

Combine basic boxes with benches for beauty and convenience on a deck, patio or in the yard.

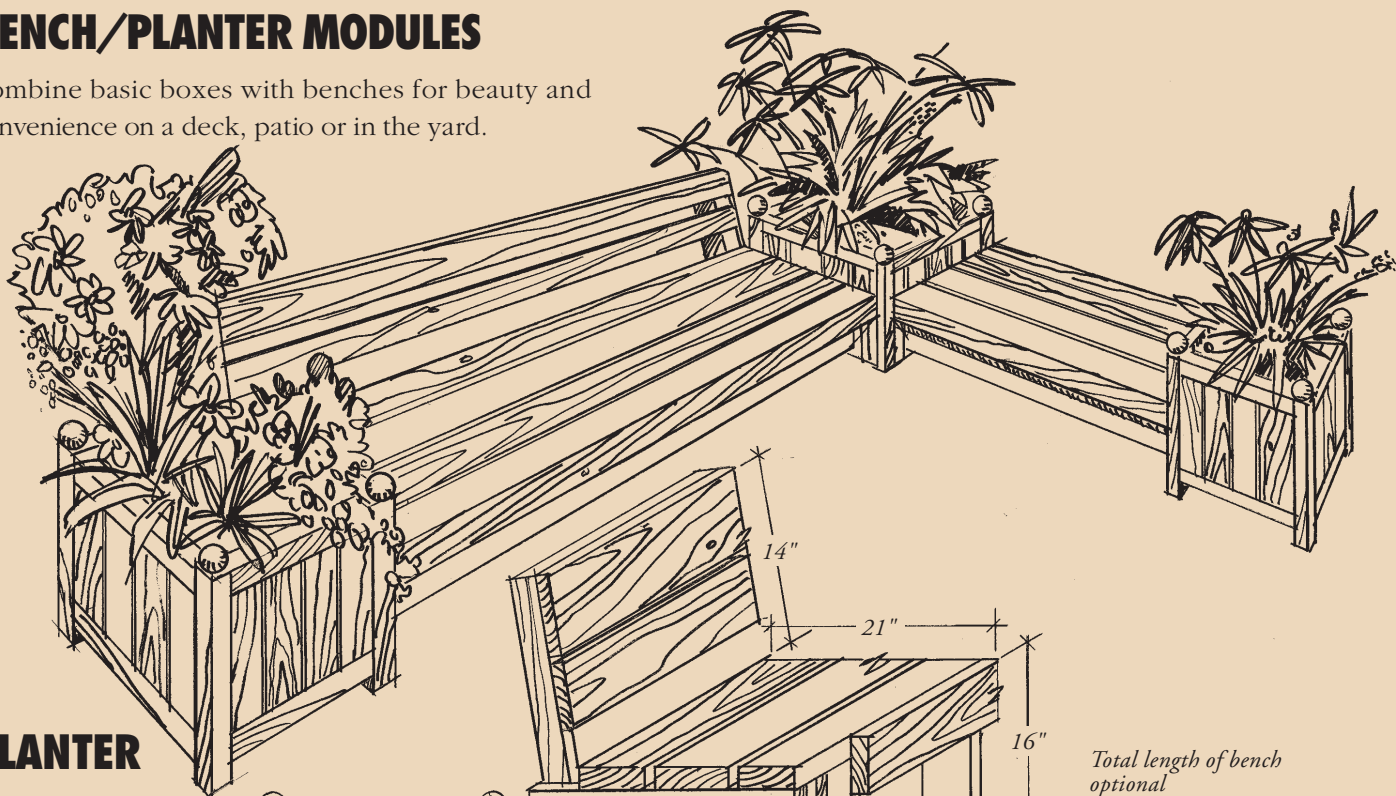

PLANTER

Use basic box construction with slightly different dimensions to fit with bench design.

For a decorative flourish, top the corner uprights with wooden finials.

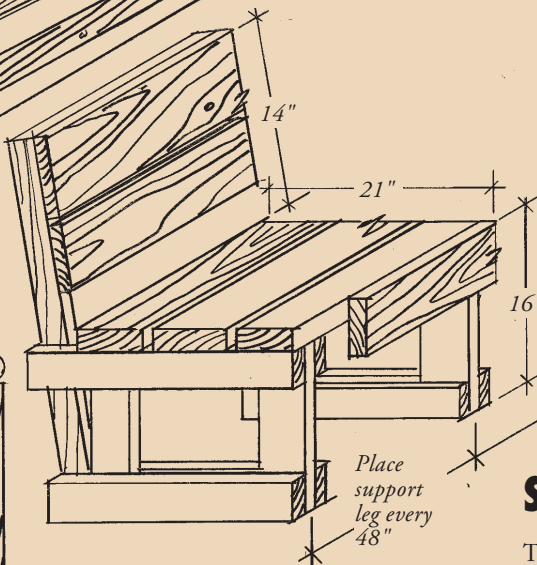
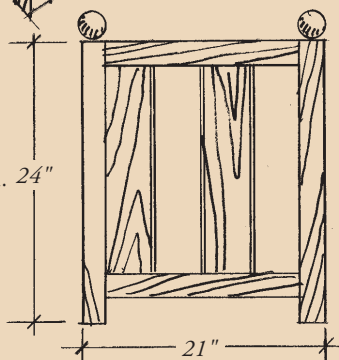

SEAT/BENCH

The sturdy garden seat features an inclined backrest. Omit backrest to create a simple bench.

PLANTING IN PLANTERS

Fill your planters with a lightweight, fast-draining planting mix. One with plenty of peat and vermiculite is ideal. In this excellent rooting medium, you can probably plant more closely than in the open garden, but give woody plants such as fuchsias and hydrangeas extra root room.

After planting, water well and check moisture in the

containers daily. Some plants won't totally recover if they dry out even once. Feed with complete liquid fertilizer such as 30-10-10 a few days after planting, then every six weeks for as long as bloom continues. Pick off dead flowers as they appear.



GARDEN LOVE SEAT

This seat is designed for two, but its length can vary to fit a particular location. All the materials are strips or blocks of 2" x 4" Cedar, except for the 2" x 10" backrest. Add some cushions for color and extra comfort.

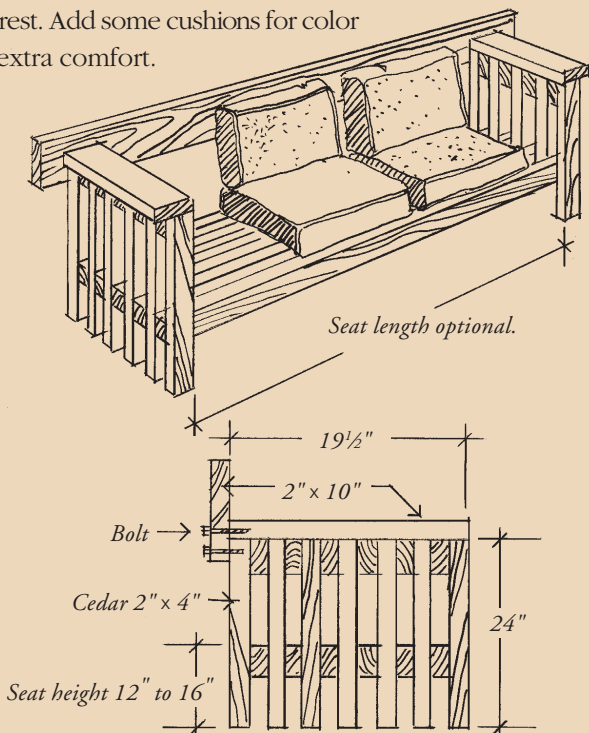

LILY POOL OR SAND BOX

To take the weight of water or sand the container is made from sturdy 2" x 6", 2" x 12" and 2" x 4" Cedar. To hold water, the inside of the box requires a polyethylene liner. Cedar has a natural preservative to resist wet and damp, but be sure to use corrosion-resistant nails and fasteners for all your outdoor Cedar projects.

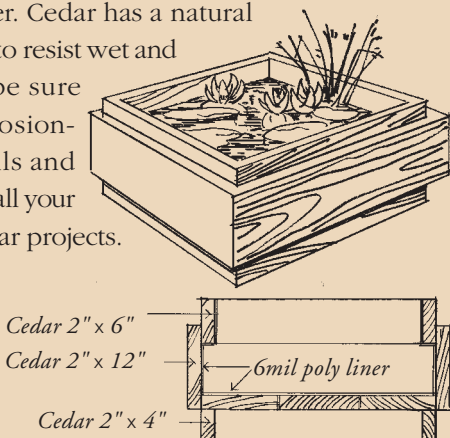

WINDOW BOX

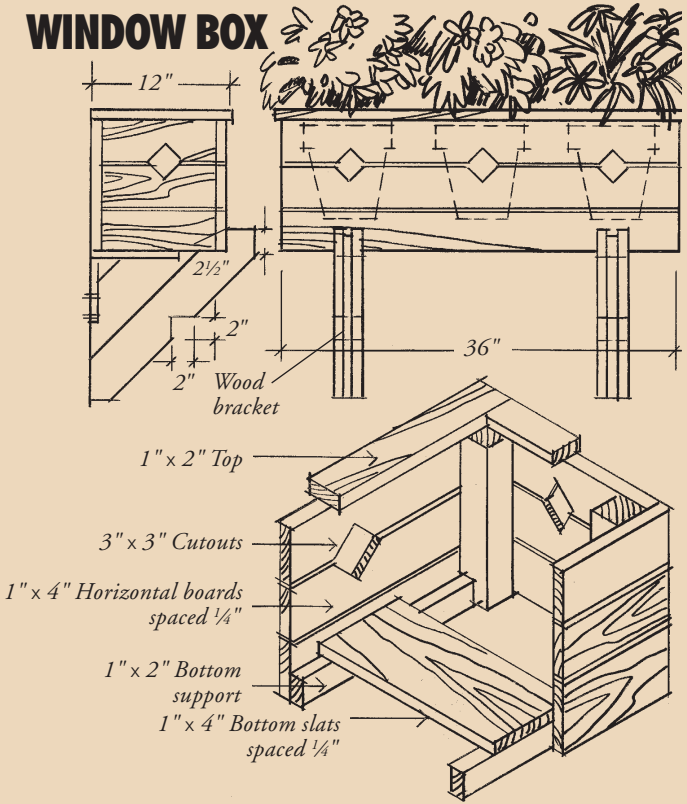

CATHEDRAL PLANTER

Start with the basic box and add a lattice back-panel as a support for climbing plants. Your building supply dealer stocks ready-made Cedar lattice panels.

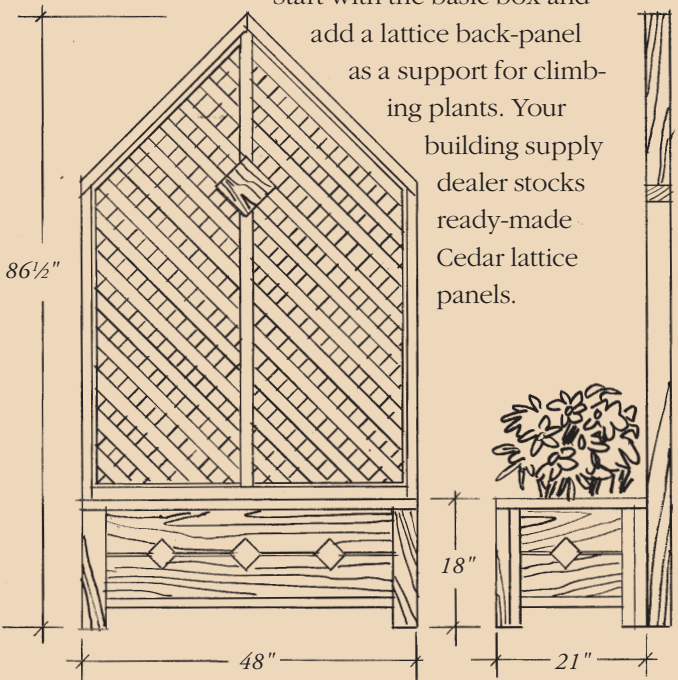

COVERED SEAT

Outdoor spaces can become useful extensions of the house to accommodate children's play activities or function as an attractive area for adult socializing. This picturesque covered seat is the perfect place to observe the natural life and rhythms of your garden. The solid V-groove Cedar around the bottom half of the structure is attractively con-

trasted with lattice above. Cedar lattice panels are available ready-made at your local building supply dealer.

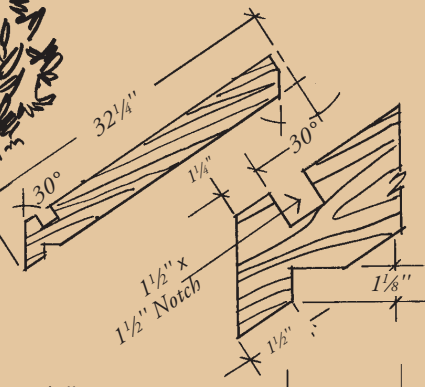
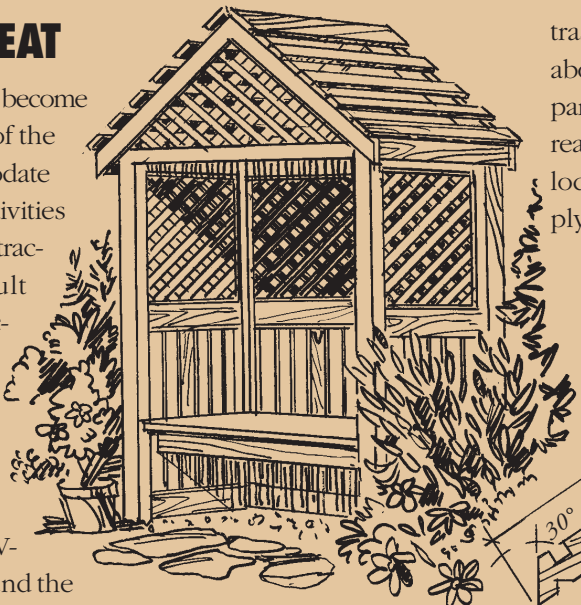

SHELTERED TABLE

This variation of the traditional picnic table features a roof to protect you from the hot sun or a cool shower. Roof construction is the same as for the Covered Seat.

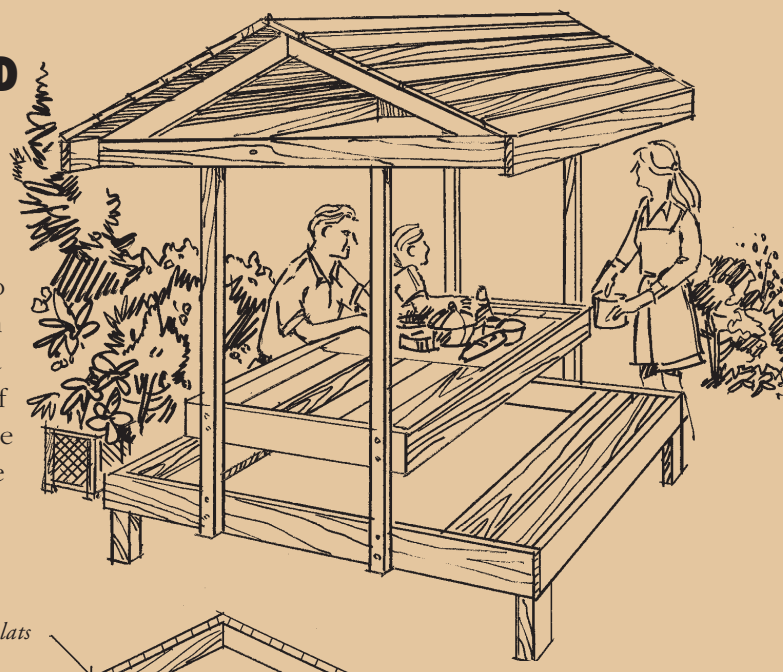

1" x 2" Cedar slats

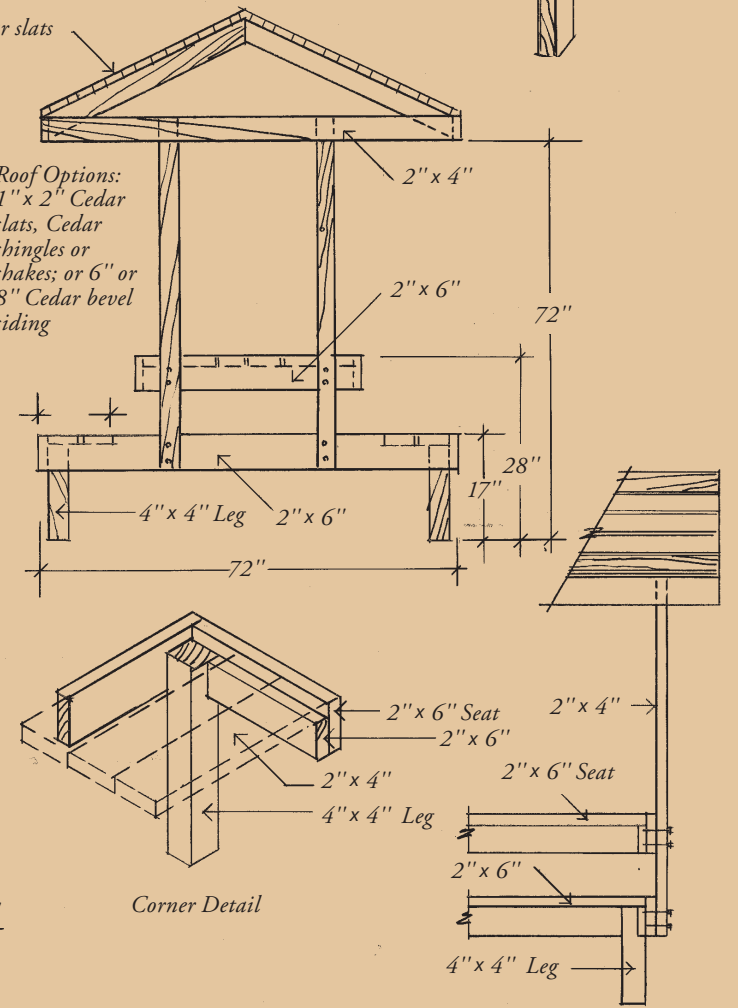
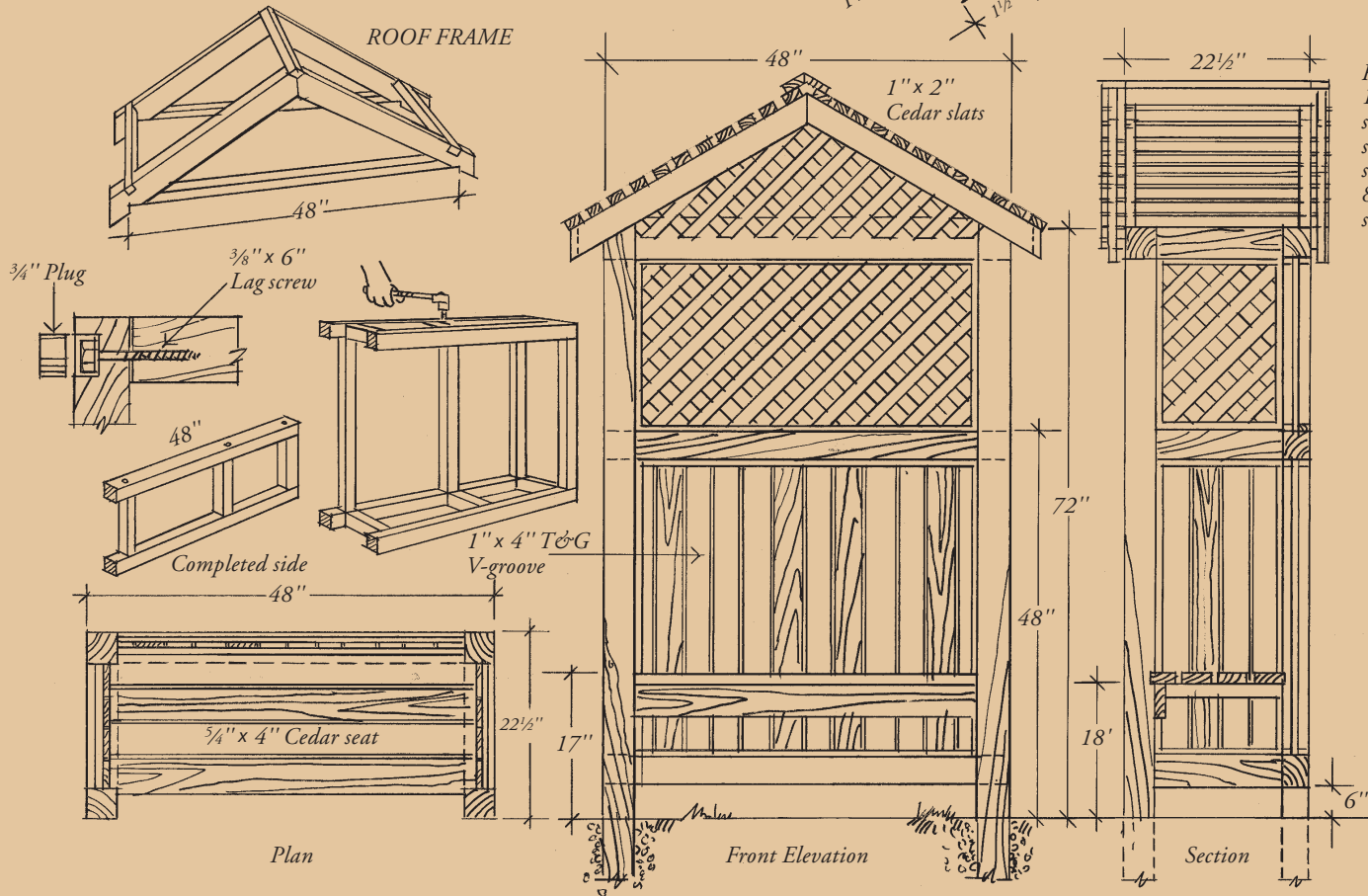

POTTING BENCH

Attractive practicality is the order of the day with this handy-dandy potting bench. The design features a recessed plastic pan to hold soil mixture flush with the bench surface – making potting and clean-up a snap.

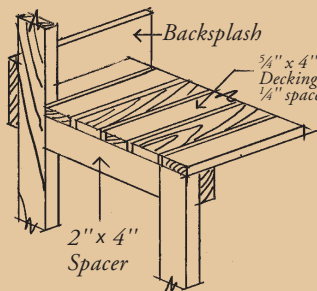
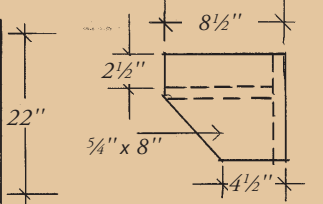
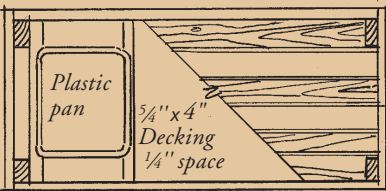
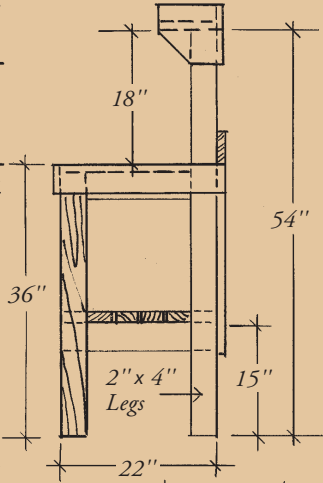
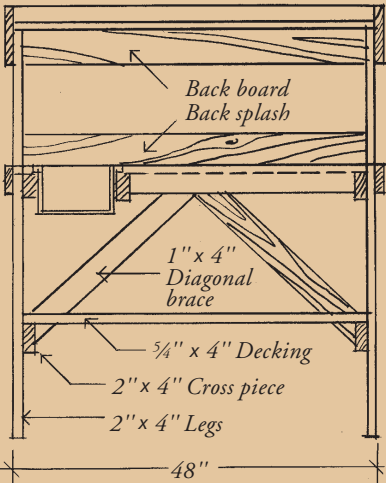

THE FINISHING TOUCH

While Cedar can be left unfinished for a rustic weathered look, the use of a quality finish recommended by your building supply dealer can enhance both its good looks and its natural characteristics.

Red Cedar accepts a wide range of stains in your choice of tinted transparent finishes for a natural effect, or lightly pigmented semi-transparent finishes. The latter are available in a spectrum of colors.

Look for a coating that offers good fungicide and ultra-violet shielding properties as well as additional preservatives to protect your project's youthful complexion. Varnishes and other film-forming coatings which can crack and peel are not recommended for use on Cedar.

CHECK OUT ALL OUR "BUILD IT RIGHT WITH REAL CEDAR" BROCHURES:

- Decks, Stairs & Railings
- Gazebos & Outbuildings
- Fences & Gates
- Planter Boxes, Benches & Tables
- Arbors, Trellises & Pergolas

REAL CEDAR OFFERS YOU EXTRA ASSURANCE:

The Western Red Cedar Lumber Association mark of quality tells you it's Real Cedar, carefully manufactured and strictly graded for your intended use.



Vancouver, BC Canada

Toll Free: 1-866-778-9096

Email: info@wrcla.org www.realcedar.org